

CLAMP CRANE™ CB3-6 EU specification

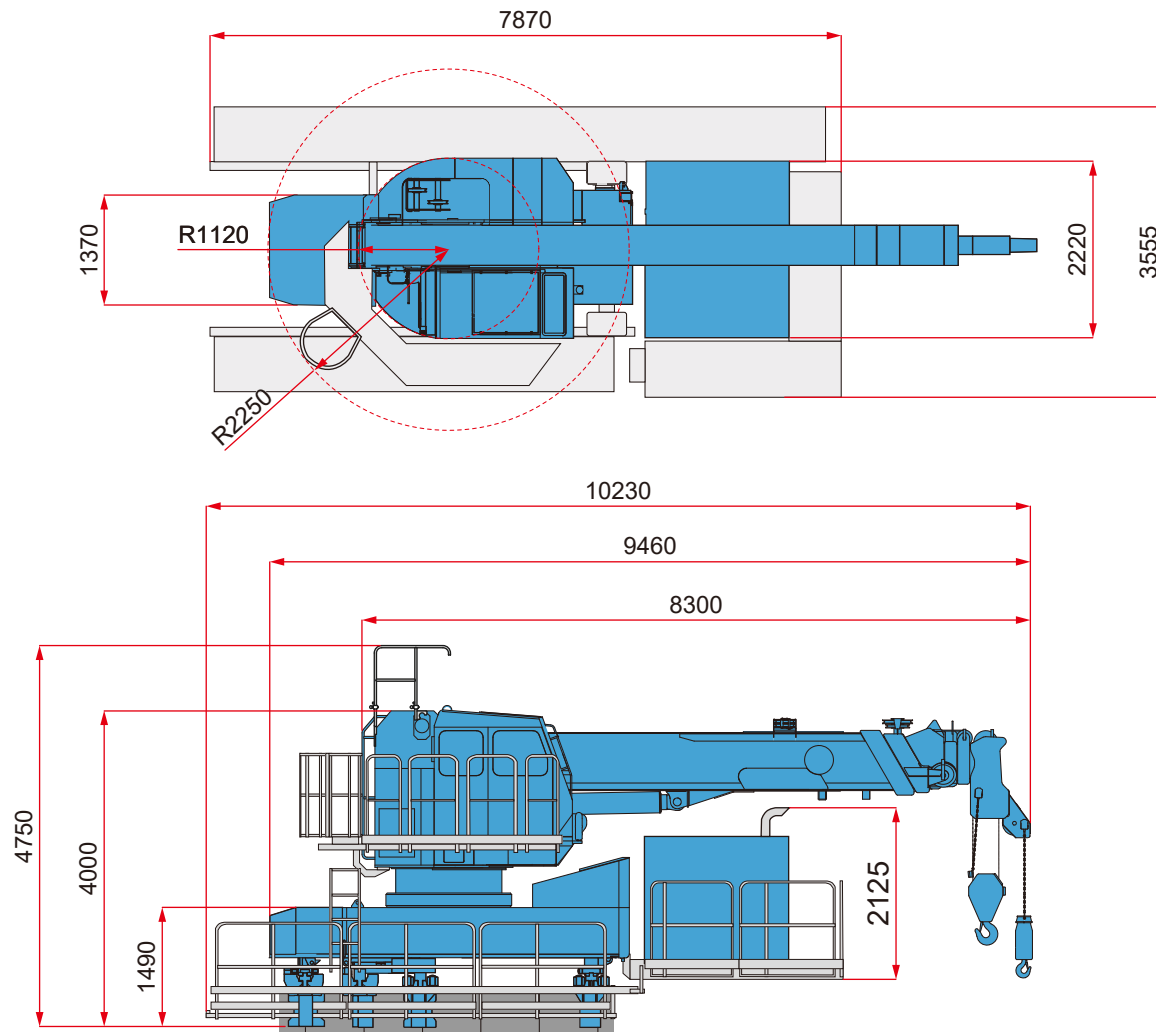

CLAMP CRANE™ CB3-6	
Applicable Reaction Piles	Z Sheet Pile 575 - 708 mm U Sheet Pile 600 - 750 mm
Lifting Capacity	10 ton x 6.5 m
Max. Working Radius	30.0 m
Crane Operation	Manual
Movement on Piles	Self-moving
Self-moving Operation	Remote Control
Power Unit	EU130A5
Power Source	Diesel Engine
Rated Output	
Power Mode	97 kW / 1800mm ⁻¹
Eco Mode	91 kW / 1600mm ⁻¹
Super Eco Mode	79 kW / 1400mm ⁻¹
Mass (including stages)	26386 kg

Specifications are subject to alteration without prior notice.